

POST CAPACITY CHART

Recommended safe loads (per post) for use only where seismic forces are not a factor

BEAM SPACING	STD. ANGLE POST CAPACITY	HEAVY ANGLE POST CAPACITY
12"	1530	1735
18"	1520	1720
24"	1510	1695
30"	1490	1680
36"	1350	1660
42"	990	1560
48"	755	1195

BEAM SPACING	STANDARD/HEAVY-DUTY POST CAPACITY
12"	5045
18"	4965
24"	4850
30"	4705
36"	4525
42"	4315
48"	4075

Post capacities are based on the maximum vertical distance between left or right beams or front-to-back beams, whichever is greater. In single rivet beam units, the vertical distance between front-to-back beams will usually govern. Tie plates must be spaced no more than 48 inches apart to insure structural stability when joining angle post together. All units require tie plates at top and bottom.

The above capacities are not intended for use when designing multi-level systems or for specific requirements where seismic forces are a factor. For specific multi-level or seismic requirements contact your Hollowell Sales Manager.

BEAM LOAD TABLE (CAPACITY PER PAIR)

Recommended safe use allowable uniformly distributed hand loaded static beam loads

	WITHOUT CENTER. SUPTS.(***)			WITH CENTER. SUPTS.(*)	
	LENGTH (IN.)	CAPACITY (LBS.)	DEFLECTION (IN.)	CAPACITY (LBS.)	DEFLECTION (IN.)
SINGLE RIVET SHELF BEAMS					
STANDARD BEAM	36	350	0.25	-	-
	42	300	0.30	-	-
	48	250	0.34	-	-
HEAVY DUTY BEAM	36	600	0.25	-	-
	42	550	0.30	-	-
	48	500	0.34	-	-
DOUBLE RIVET ANGLE BEAMS					
STANDARD BEAM	36	1000	***	-	-
	42	780	***	-	-
	48	500	***	875*	0.12
	48	750	***	1400**	0.16
	60	600	***	1200	0.25
HEAVY DUTY BEAM	69	525	***	1050	0.33
	72	500	***	1000	0.36
	84	-	-	840	0.49
	96	-	-	620	0.53
DOUBLE RIVET CHANNEL					
	60	-	-	2240	0.23
	72	-	-	1850	0.33
	84	-	-	1600	0.45
	96	-	-	1400	0.59
DOUBLE RIVET Z-BEAM					
	48	1250	-	1750	-
	60	750	-	1000	-
	69	600	-	1000	-
	72	600	-	1000	-

DESIGN CRITERIA:

All units must have a full perimeter of double rivet beams at the top and bottom to insure a stable and rigid unit. All units using single rivet beams 10'0" to 18'0" in height, require an additional double rivet perimeter beam level located approximately in the middle of the unit.

All single rivet beam units must have one (1) intermediate pair of front to back beams for 7'0" and 8'0" high units and (2) intermediate pair of front to back beams for 9'0" high units. For 10'0" to 18'0" high units refer to the above paragraph. **DO NOT exceed 48" between front to back beams.** Single Rivet and Double Rivet-Front-to-Back Beams may be common when using T-Posts on units up to 8' high.

All intermediate single rivet levels over 24 inches deep must also have single rivet beams supporting the particle board front to back.

All double rivet beam units must have front to back beams at each shelf level.

(*) One (1) support per pair of beams except 96" which have two (2) supports

(**) Refer to shelf load capacities for beam capacities when depth is 30", 36" and 48".

(***) Beam rotation is less than 5 degrees.

Recommended safe use load table for 5/8" particle board and EZ-Deck steel decking allowable uniformly distributed static live loads for deck material

Size (inches) W x D	Particle Board Decking	EZ-Deck Steel Decking	2 Sides Supported		4 Sides Supported		4 Sides + Center Supported		4 Sides + 2 Center Supported	
			LOAD (lbs.)	DEFL (ins)	LOAD (lbs.)	DEFL (ins)	LOAD (lbs.)	DEFL (ins)	LOAD (lbs.)	DEFL (ins)
36x12	HPB3612	HEZD3612	425	0.06	675	0.08				
36x18	HPB3618	HEZD3618	400	0.17	550	0.18				
36x24	HPB3624	HEZD3624	305	0.30	435	0.23				
36x30	HPB3630	HEZD3630	250	0.47	385	0.32				
36x36	HPB3636	HEZD3636	150	0.50	180	0.39				
42x12	HPB4212	HEZD4212	490	0.06	755	0.08				
42x18	HPB4218	HEZD4218	460	0.17	600	0.18				
42x24	HPB4224	HEZD4224	355	0.30	500	0.29				
42x30	HPB4230	HEZD4230	300	0.47	410	0.36				
42x36	HPB4236	HEZD4236	175	0.50	385	0.45				
48x12	HPB4812	HEZD4812	560	0.06	850	0.08	1160	0.08		
48x18	HPB4818	HEZD4818	525	0.17	635	0.18	770	0.10		
48x24	HPB4824	HEZD4824	405	0.30	530	0.30	700	0.11		
48x30	HPB4830	HEZD4830	325	0.47	440	0.40	705	0.12		
48x36	HPB4836	HEZD4836	200	0.50	400	0.50	755	0.12		
48x48	HPB4848	HEZD4848	85	0.50	275	0.50	920	0.13		
60x18	HPB6018	HEZD6018	660	0.17	735	0.18	835	0.12	1140	0.08
60x24	HPB6024	HEZD6024	505	0.30	615	0.32	700	0.15	1180	0.10
60x30	HPB6030	HEZD6030	410	0.47	520	0.46	650	0.16	1324	0.11
60x36	HPB6036	HEZD6036	250	0.50	380	0.50	665	0.17	1520	0.12
60x48	HPB6048	HEZD6048	105	0.50	230	0.50	750	0.18	2000	0.14
60x15	HPB6915	HEZD6915	900	0.11	950	0.12	1150	0.12	1250	0.11
60x30	HPB6930	HEZD6930	470	0.50	600	0.50	670	0.20	1220	0.13
72x18	HPB7218	HEZD7218	800	0.17	850	0.17	1000	0.15	1200	0.10
72x24	HPB7224	HEZD7224	605	0.30	680	0.31	770	0.19	1135	0.12
72x30	HPB7230	HEZD7230	500	0.47	610	0.50	680	0.21	1200	0.14
72x36	HPB7236	HEZD7236	300	0.50	390	0.50	655	0.23	1325	0.16
72x48	HPB7248	HEZD7248	130	0.50	215	0.50	685	0.25	1670	0.18
84x24	HPB8424	HEZD8424	705	0.30	765	0.31	870	0.23	1150	0.15
84x30	HPB8430	HEZD8430	570	0.47	650	0.49	735	0.27	1150	0.18
84x36	HPB8436	HEZD8436	355	0.50	415	0.50	670	0.29	1210	0.20
84x48	HPB8448	HEZD8448	150	0.50	215	0.50	660	0.33	1460	0.23
96x18	HPB9618	HEZD9618	1050	0.17	1115	0.17	1300	0.18	1500	0.15
96x24	HPB9624	HEZD9624	810	0.30	850	0.31	1000	0.26	1200	0.18
96x30	HPB9630	HEZD9630	655	0.47	710	0.49	800	0.32	1180	0.20
96x36	HPB9636	HEZD9636	405	0.50	450	0.50	710	0.36	1150	0.24
96x48	HPB9648	HEZD9648	170	0.50	200	0.50	650	0.41	1325	0.28

NOTE: The above load chart refers to the deck materials only. Particle board decking is 5/8" industrial grade type 1-M-2. EZ-Deck steel decking is 22 gauge galvanized sheet steel fabricated in 6" deep channel planks (models listed above include multiple planks to meet unit depth). The allowable shelf load capacity may be reduced due to allowable column and / or beam capacities. Specific deflection limits may also reduce the shelf load capacity. 15" deep Ez-Deck will be shipped in two (2) 7 1/2" deep planks. **NOTE: EZ-Deck must be center support on units 48" wide and wider.**

Particle Board Decking

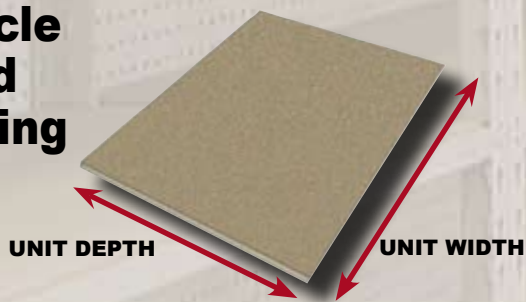

EZ-Deck Steel Decking

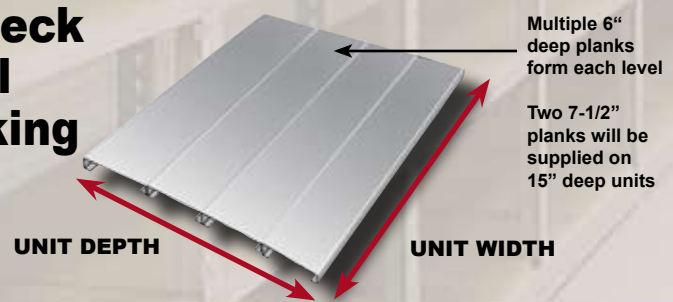

UNIT GROWTH CHART

When designing a shelving layout, Unit growth must be considered. To determine the overall dimension of a continuous row of shelving employing T-Posts or Angle Posts with tie plates, refer to the table below.

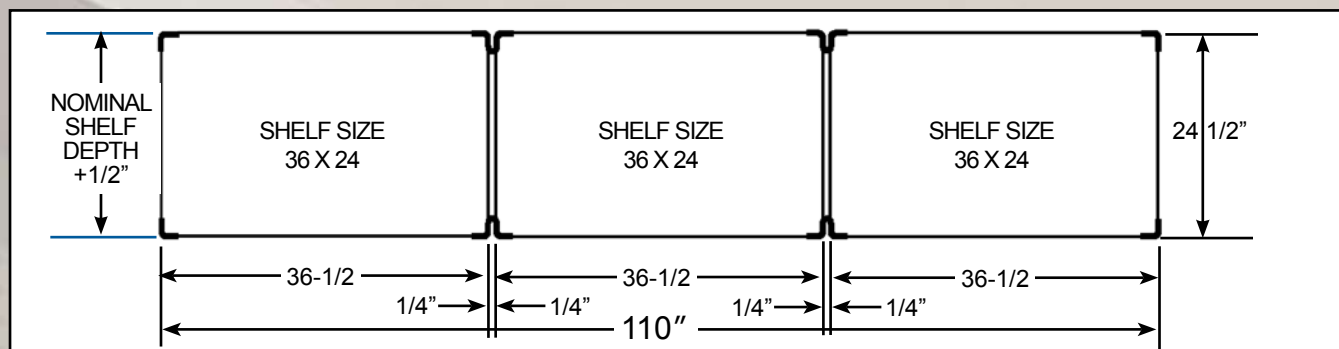

UNIT CLEAR WIDTH

Examples below are based on 36" wide shelf.

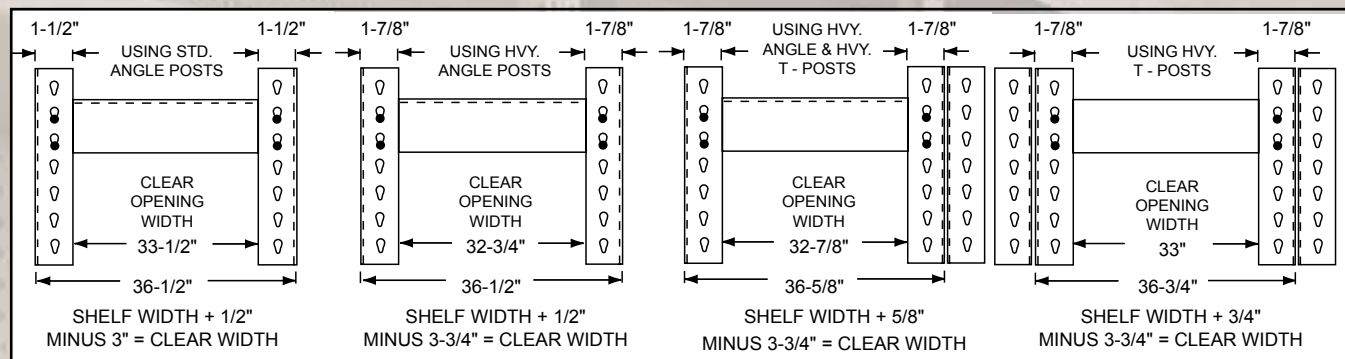

VERTICAL SHELF CLEARANCE FOR SINGLE RIVET UNITS

This chart depicts shelf clearances for typical rivetwell shelving units with 1-1/2" vertical shelf adjustment

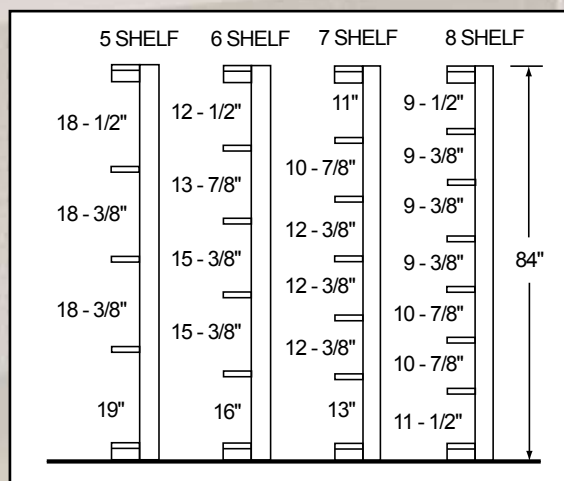

VERTICAL SHELF CLEARANCE FOR DOUBLE RIVET UNITS

