

# Schaefer Universal System Design Cart

Model USD is for use with standard bar-lock lifters or automated grabbers.



**Body**

### Body

- Non-slip, textured finish on corners for grabber efficiency
- Long-lasting, integrated lid hinges
- Smooth surface inside and out for easy maintenance
- Injection molded for maximum strength and durability
- One-piece high-density polyethylene (HDPE) construction
- Built-in flexibility (M Only)



**Bar**

### Bar

- Highly durable, in-molded bar supports
- Freely rotating recycled bar for less stress on cart body
- Installed by factory personnel
- Extra wall thickness in bar area for durability



**Upper Attachment**

### Upper Attachment

- Integrated, reinforced upper attachment for semi-automated lifters
- Structurally designed per ANSI Standards



**Lids**

### Lids - USD 95M

- Overlapping lip for rain protection
- Inside dripping rim to seal in odors
- 270° lid opening
- Sturdy, comfortable safe ergonomic handles (2)

### Handles

- Ergonomically designed hand grips for ease of pushing/pulling the cart
- Smooth surface with no protrusions
- 2" x 5" opening for easy gripping
- RFID Ready

### Wheels & Axles

- Axle of tempered, rolled, Zink Chromate steel
- Maintenance-free bearings lubricated for life
- 10" or 12" wheels available for 95M-gallon model
- 10" wheels on 65-gallon model
- 8" wheels on 35-gallon model

### Bottom

- In-molded toe hold to ease tilting of loaded cart
- 0.375" wear strip for longer life

### Colors & Marking

- Available in green, blue, brown and charcoal
- Custom colors available
- Smooth surface for hot stamping on lid and body

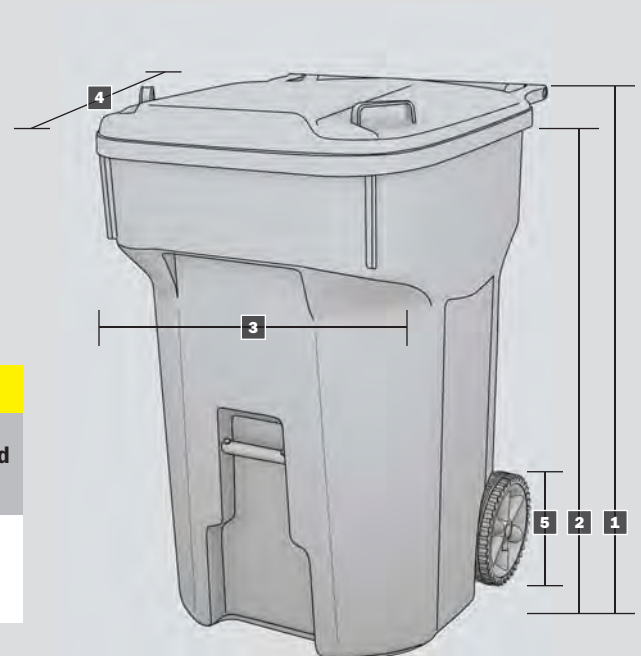

## Universal System Design Cart (measurements in inches, unless specified)

| Order #        | Dimensions |                |   |       | Wheel Diameter | Load Rating<br>lbs. ▼ | Full Truckload |      |   |    |     |      |
|----------------|------------|----------------|---|-------|----------------|-----------------------|----------------|------|---|----|-----|------|
|                | H          | H<br>Cart Body | W | D     |                |                       |                |      |   |    |     |      |
| <b>USD 35</b>  | 1          | 38.2           | 2 | 35.8  | 3              | 22.8                  | 4              | 22.3 | 5 | 8  | 125 | 1008 |
| <b>USD 65</b>  |            | 42.2           |   | 39.5  |                | 25.9                  |                | 26.5 |   | 10 | 220 | 660  |
| <b>USD 95M</b> |            | 44.3           |   | 41.06 |                | 27.6                  |                | 31.5 |   | 10 | 330 | 549  |