

Schaefer Universal System Design Cart

Model USD is for use with standard bar-lock lifters or automated grabbers.



Body

Body

- Non-slip, textured finish on corners for grabber efficiency
- Long-lasting, integrated lid hinges
- Smooth surface inside and out for easy maintenance
- Injection molded for maximum strength and durability
- One-piece high-density polyethylene (HDPE) construction
- Built-in flexibility (M Only)



Bar

Bar

- Highly durable, in-molded bar supports
- Freely rotating recycled bar for less stress on cart body
- Installed by factory personnel
- Extra wall thickness in bar area for durability



Upper Attachment

Upper Attachment

- Integrated, reinforced upper attachment for semi-automated lifters
- Structurally designed per ANSI Standards



Lids

Lids - USD 95M

- Overlapping lip for rain protection
- Inside dripping rim to seal in odors
- 270° lid opening
- Sturdy, comfortable safe ergonomic handles (2)

Handles

- Ergonomically designed hand grips for ease of pushing/pulling the cart
- Smooth surface with no protrusions
- 2" x 5" opening for easy gripping
- RFID Ready

Wheels & Axles

- Axle of tempered, rolled, Zink Chromate steel
- Maintenance-free bearings lubricated for life
- 10" or 12" wheels available for 95M-gallon model
- 10" wheels on 65-gallon model
- 8" wheels on 35-gallon model

Bottom

- In-molded toe hold to ease tilting of loaded cart
- 0.375" wear strip for longer life

Colors & Marking

- Available in green, blue, brown and charcoal
- Custom colors available
- Smooth surface for hot stamping on lid and body

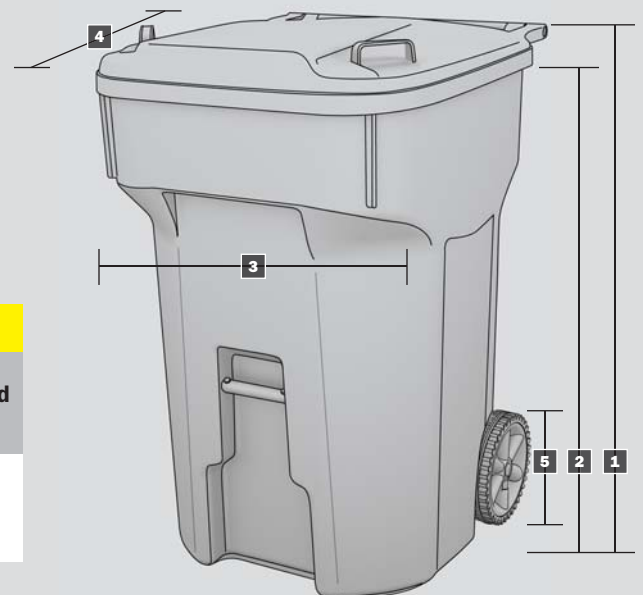

Universal System Design Cart (measurements in inches, unless specified)

Order #	Dimensions				Wheel Diameter	Load Rating lbs. ▼	Full Truckload
	H	H Cart Body	W	D			
USD 35	1 38.2	2 35.8	3 22.8	4 22.3	5 8	125	1008
USD 65	42.2	39.5	25.9	26.5	10	220	660
USD 95M	44.3	41.06	27.6	31.5	10	330	549